

DRIVEWAY WIDTH RESIDENTIAL (12'-24' MAX) COMMERCIAL (24'-35' MAX)

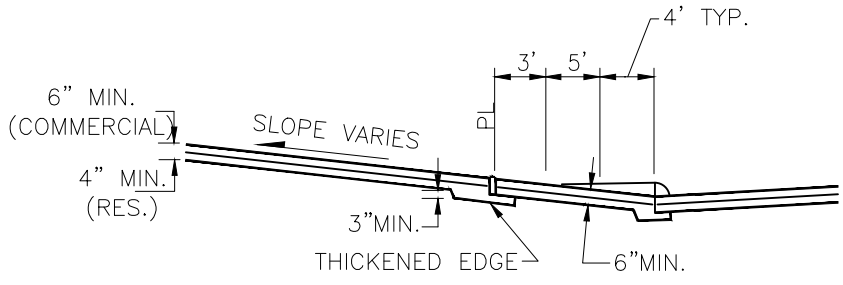
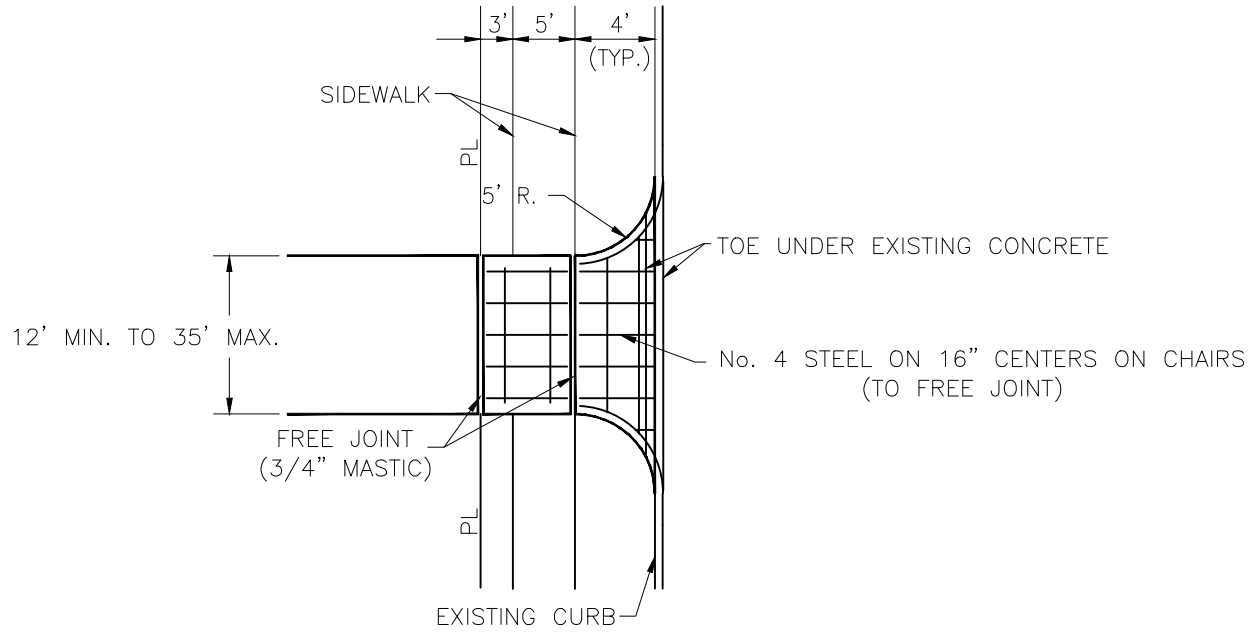

- * NOTES:
- 1) CITY STREETS ONLY. NO CUTOUTS ARE PERMITTED ON TEXAS STATE HIGHWAYS.
 - 2) ALL CUTOUTS MUST HAVE BARRICADES INSTALLED UNTIL DRIVEWAYS ARE POURED.
 - 3) ALL DRIVEWAYS IN STATE R.O.W. REQUIRE TXDOT TRAFFIC CONTROL PLAN PRIOR TO BEGINNING CONSTRUCTION.

CITY OF DICKINSON, TEXAS

DRIVEWAY DETAIL
 CONCRETE DRIVEWAY
 TO CURB AND
 GUTTER STREET

REVISED
 APRIL 2020

SD-2